

RIB AND BLOCK FACTS



A rib and block slab is composed of rectangular shaped precast concrete reinforced ribs supporting rebated filler blocks placed between two ribs. This system is sometimes called the beam and block system. In-situ concrete is poured between and over the blocks and ribs.

The slab -

Overall slab depths vary from 175mm to 380mm depending on a number of factors. Spans of ribs may vary, and can comfortably be transported at lengths of up to 6.5m, and longer with prior arrangement.

The choice of the thickness of the slab is determined by the engineer and amongst others the choice of the rebated filler blocks and the thickness of the In Situ concrete.

The blocks -

The following blocks sizes are available – 90mm high, 140mm high and 200mm high. All blocks are 500mm wide and 200mm deep.

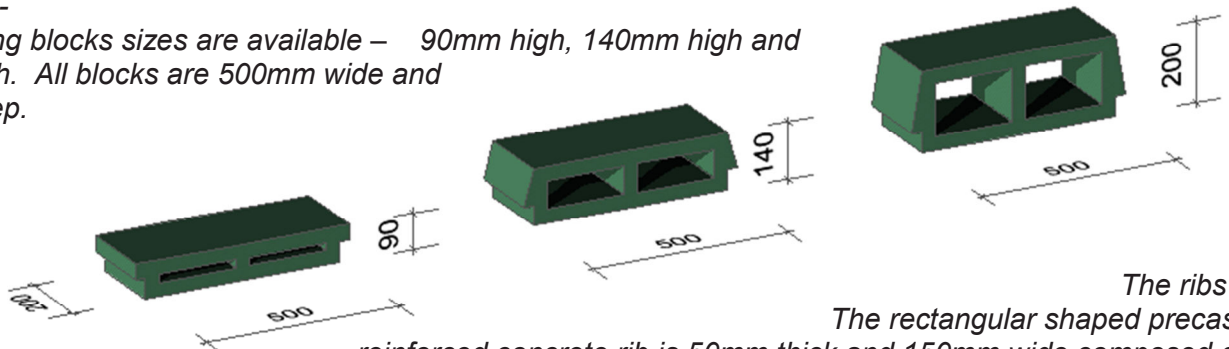

The ribs -

The rectangular shaped precast reinforced concrete rib is 50mm thick and 150mm wide composed of a lattice girder and main tension reinforcing. The latter is designed by the Structural Engineer and is high yield reinforcing bars in standard diameters of 10, 12, 16, 20mm. The top reinforcing bar of the composed lattice girder is 8mm Ø while the angled strands are 5.6mm. The overall height (h) of the lattice is generally 100mm.

The lattice girder -

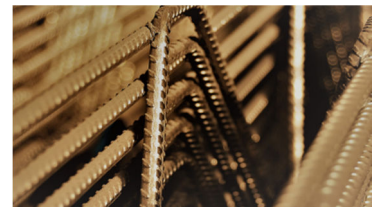
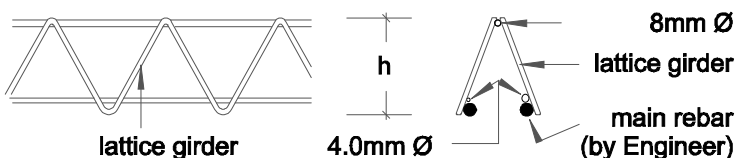

The system –

Benefits of the rib and block system includes –

- Speed of erecting the slab.
- Thermal properties incorporating hollow blocks.
- Engineered designed slab system
- Pricing is economically viable.
- Quality is factory controlled.
- Excellent technical support.

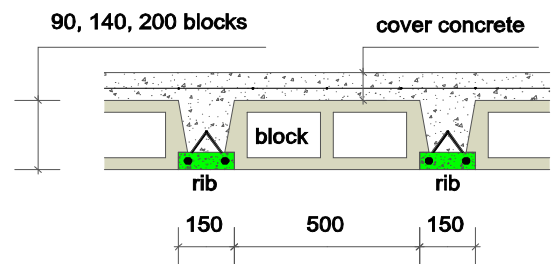

The application –

The application of rib and block is not limited to Commercial and industrial buildings only, but is often used and preferred by home builders, over other slab systems.

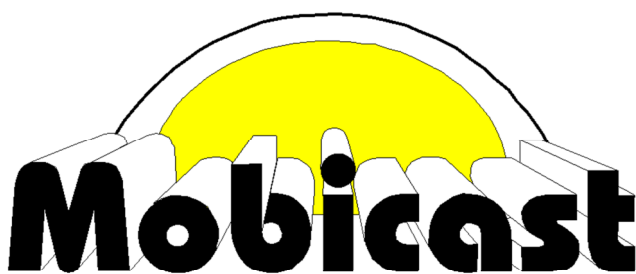

Bricks – Blocks – Pavers – Kerbs - Lintels

Leiers in Diens en Innovasie
Leaders in Service and Innovation

**FOR ENQUIRIES OR TO PLACE AN ORDER
CONTACT MOBICAST AT 086 111 2346 OR
VISIT US AT www.mobicast.co.za**